



A^{RF43} Data modem



User Guide

No part of this document may be reproduced or transmitted (in electronic or paper version, photocopy) without Adeunis RF consent.

This document is subject to change without notice.

All trademarks mentioned in this guide are the property of their respective owner.

ADEUNIS RF

283, rue Louis Néel

38920 Crolles

France

Phone +33 (0)4 76 92 07 77

Fax +33 (0)4 76 08 97 46

Ref. 08-07-V16-lmn

Table of contents

About this document	2
Declaration of conformity	3
Overview	4
Product power supply	4
Serial link wiring	5
MODEM / DTE RS232	5
DCE RS232	6
RS485 wiring.....	7
Radio communication	9
Radio communication	9
Radio channel	10
Channel adjustment	12
Radio rate selection.....	12
Channel rejection	13
RSSI reading.....	13
Antenna versions.....	14
Modem operating mode	14
Command mode.....	14
Transceiver mode.....	16
Transparent mode.....	16
Addressed mode	17
Set of commands	17
Set of commands	18
Register description	19
Specifications	24
Firmware update	26

About this document

This guide describes the A^{RF43} devices, their options and accessories.

Declaration of conformity



Manufacturer's name: **ADEUNIS R.F.**
 Manufacturer's address: Parc Technologique PRE ROUX IV
 283 rue Louis NEEL
 38920 CROLLES - FRANCE

declares that the product if used and installed according to the user guide available on our web site www.adeunis-rf.com

Product Name: **ARF43**
 Product Number(s): **ARF7263E / ARF7263G / ARF7263F / ARF7263H**
 Product options:

complies with the RTTE Directive 99/5/EC:

EMC: conformity is proven by compliance to the harmonized standard EN 301-489
 Safety: conformity to the standard EN 60950-1/2001
 Radio: conformity is proven by compliance to harmonized standard EN 300-220 covering essential radio requirements of the RTTE directive.

Exposure to radio frequency signals: Regarding the 1999/519/EC recommendation, when using the device, keep the product at least 4 cm from your body.

Notes: - Conformity has been evaluated according to the procedure described in Annex III of the RTTE directive.
 - Receiver class (if applicable): 3.

Crolles, November 6th, 2007
 VINCENT Hervé / Quality manager

A handwritten signature in black ink, appearing to be 'V. Hervé'.

Download of the user guide

Thank you for having chosen the ADEUNIS RF products.
 User guides can be uploaded directly on our web site www.adeunis-rf.com

Index **Products**
 Paragraph **Modems > Data modem**

Print version available upon request

- ✓ Tel : +33 4 76 92 07 77
- ✓ Email : arf@adeunis-rf.com

Overview

The modem converts data from a serial link into a radio frame to be sent to a similar piece of equipment.

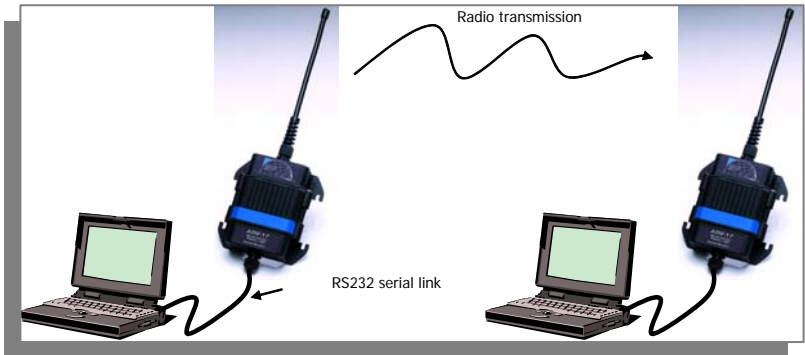

The operating parameters of these modems (serial link, radio management...) can be updated through commands on the serial link.

The products are available either in card version to be integrated in an assembly or as an IP65 chip. In the IP65 case, the products are fixed with the fixing lugs onto the top (antenna) and bottom (stuffing box) of the casing (4 screws not provided).

Product power supply

To perform wiring of these products, the bottom part of the housing (part with stuffing box) has to be opened by unscrewing the two stainless steel screws on each side.

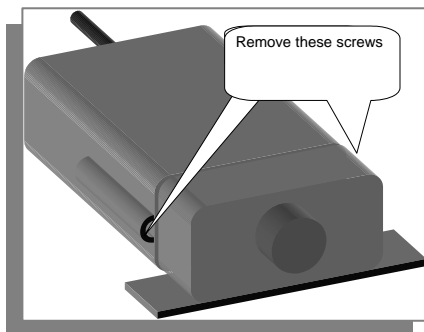

The ARF43 range products are supplied from a DC voltage source. This voltage source must be 8 V minimum and must not exceed 32 Vdc.

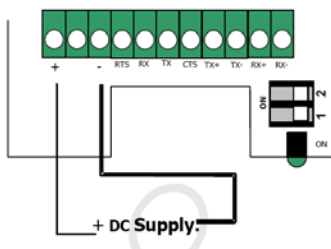

EASY CHECK

Green LED is ON when modem is powered.

Serial link wiring

MODEM / DTE RS232

This is for example the case of a modem connected to a PC. RTS and CTS are required only if flow control is used.

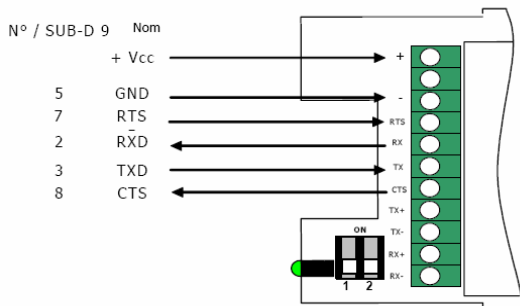

DCE RS232

This is for example the case of a modem connected to a measuring device. RTS and CTS are required only if flow control is used.

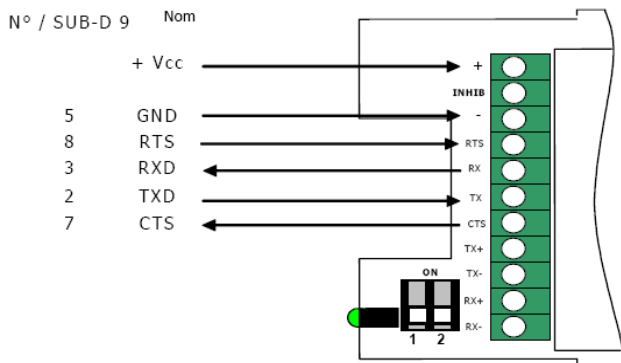

RS485 wiring

The RS485 bus wiring needs only two wires (TX+ is connected to RX+ and TX- is connected to RX- on the PCB)

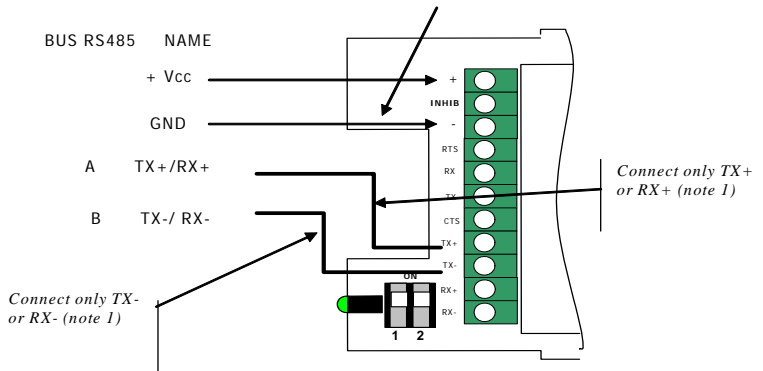

Note 1:

- TX- is connected to RX- on the PCB
- TX+ is connected to RX+ on the PCB

Figure 1 : RS485 wiring

In order to activate the RS485 management the SW1.1 switch MUST be ON and the S215 value MUST be 1 (see the following table).

WARNING

The SW1.1 switch is read only at the power-up. Changing the SW1.1 switch when the modem is already running will not be taken in account.

S215 value	SW1.1	Note
1	ON	RS485 control lines management
1	OFF	RS232 configuration
0	Ignored	RS232 configuration

Table 1 : R485/232 configuration settings

By default the DE and RE lines are asserted LOW, allowing receiving character from the RS485 differential bus. The DE and RE lines are asserted HIGH only when one or several characters have to be transmitted over the RS485 differential bus: when a radio frame is demodulated, the lines are asserted HIGH and then the data extracted from the radio frame are sent to the module TXD line and therefore to the RS485 differential bus. When the last character has been transmitted over the RS485 differential bus, the lines are asserted LOW.

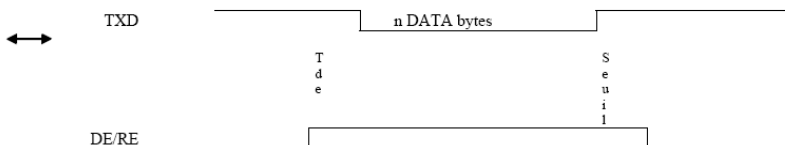

Figure 2 : DE/RE timing when data are sent over the serial link

Threshold: minimum = 1 μ s

Tde: set according to the S219 register value (see table hereafter)

S219	0	1	2	3	4	5	10	20	40	60	80
Tde min	20 μ s	40 μ s	60 μ s	80 μ s	100 μ s	110 μ s	250 μ s	480 μ s	900 μ s	1.3 ms	1.7 ms

The RS485 link needs to be adapted (each side). The modem includes a 100 Ω termination resistor :

SW1.2 = ON, the resistor is connected between A and B (respectively RX+ and RX-)

SW1.2 = OFF, the resistor is not connected between A and B.

If the modem is ending the RS485 bus, SW1.1 must be ON.

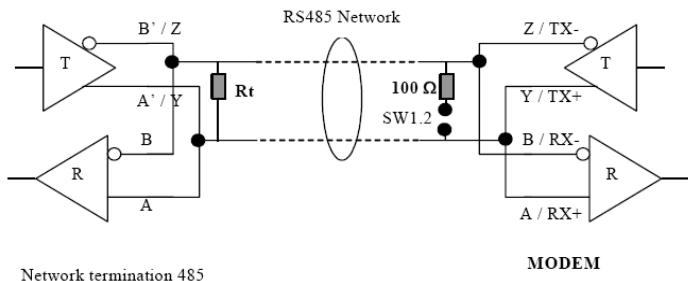

EASY CHECK

Serial link activity will make the green LED flashing, whatever the selected data rate is right or wrong.

Radio communication

Radio communication

This modem has several channels over the 863-870 MHz Band that can be selected using AT commands, distributed in Wide Band and Narrow Band.

Wide Band channel:

14 Wide Band channels (first set of channels from 0 up to 13)

57.6 kbit/s

channel spacing: 500 kHz

Sensitivity: - 103 dBm

Adjacent channel rejection: see chapter ["Channel rejection"](#)

Narrow Band channel:

70 Narrow Band channels (second set of channels from 14 up to 83)

10 kbit/s radio rate

channel spacing: 100 kHz

Sensitivity: - 105 dBm

Adjacent channel rejection : see chapter [“Channel rejection”](#)

This module is designed to operate according to CEPT/ERC/REC 70-03 recommendation. This recommendation has been drawn up by the European Radio communications Committee (ERC) under CEPT.

A new frequency allocation in Europe, for the 863 to 870 MHz band, is in progress. When this new frequency allocation will be approved, the proposed 863-870 channels should be used according to these new recommendations.

The RF out power could be adjusted using AT commands (see register S231).

Radio channel

The 14 Wide Band channels are selected according to the following table:

Channel S200	Frequency (MHz)
13	863,25
12	863,75
11	864,25
10	864,75
9	865,25
8	865,75
7	866,25
6	866,75
5	867,25
4	867,75
3	868,25
2	868,75
1	869,525
0	869,75

Figure 1: Wide band channels

The 70 Narrow Band channels are selected according to the following table:

Channel S200	Frequency (MHz)	Channel S200	Frequency (MHz)	Channel S200	Frequency (MHz)
83	863,05	60	865,35	37	867,65
82	863,15	59	865,45	36	867,75
81	863,25	58	865,55	35	867,85
80	863,35	57	865,65	34	867,95
79	863,45	56	865,75	33	868,05
78	863,55	55	865,85	32	868,15
77	863,65	54	865,95	31	868,25
76	863,75	53	866,05	30	868,35
75	863,85	52	866,15	29	868,45
74	863,95	51	866,25	28	868,55
73	864,05	50	866,35	27	868,65
72	864,15	49	866,45	26	868,75
71	864,25	48	866,55	25	868,85
70	864,35	47	866,65	24	868,95
69	864,45	46	866,75	23	869,05
68	864,55	45	866,85	22	869,15
67	864,65	44	866,95	21	869,25
66	864,75	43	867,05	20	869,35
65	864,85	42	867,15	19	869,45
64	864,95	41	867,25	18	869,55
63	865,05	40	867,35	17	869,65
62	865,15	39	867,45	16	869,75
61	865,25	38	867,55	15	869,85
				14	869,95

Figure 2: Narrow Band channels

Currently and according to CEPT/ERC/REC 70-03 recommendation, the authorised channels are:

For the WB, limited to 25 mW according to above recommendation(up to 25 mW for ARF34 module): channels 2 (868.75) and 3 (868.25)

For the WB, limited to 500 mW according to above recommendation (up to 50 mW for ARF34 module): channel 1 (869.525)

For the NB, limited to 25mW according to above recommendation

(up to 25 mW for ARF34 module): channels 22 (869.15), 23 (869.05), 24 (868.95), 25 (868.85), 26 (868.75), 28 (868.55), 29 (868.45), 30 (868.35), 31 (868.25), 32 (868.15), 33 (868.05)

For the NB, limited to 500 mW according to above recommendation (up to 50 mW for ARF34 module): channels 18 (869.55), 19 (869.45).

Figures between brackets are expressed in MHz.

Channel adjustment

The S200 register allows choosing the desired channel and the associated radio rate (see chapter “[Channel rejection](#)”).

When the S200 channel register is written (even with the same value) or set to its default value (see ATR command), the on chip radio parameters must be updated and a radio chip calibration is required.

These update and calibration take up to 90ms (nominally 30ms); during this time the transceiver is not able to receive or transmit any data → all incoming RS232 data will be ignored (silently discarded).

This update and calibration are performed:

When leaving the command mode (issuing ATO command)

Or when an ATTx command is issued

This is done for insuring that the radio chip is working with the appropriate configuration.

Radio rate selection

For 868 / 870 MHz version, the Radio rate selection is automatically done when setting the channel number:

If you choose a channel number ≥ 14 (Narrow Band), the radio rate will automatically switch to 10 kbit/s.

If you choose a channel number < 14 , the module will operate in the Wide Band configuration. The radio rate will switch automatically to 57600 bit/s.

Channel rejection

The graph below shows the typical channels rejection of ARF43 in WideBand (WB) and NarrowBand (NB) modes.

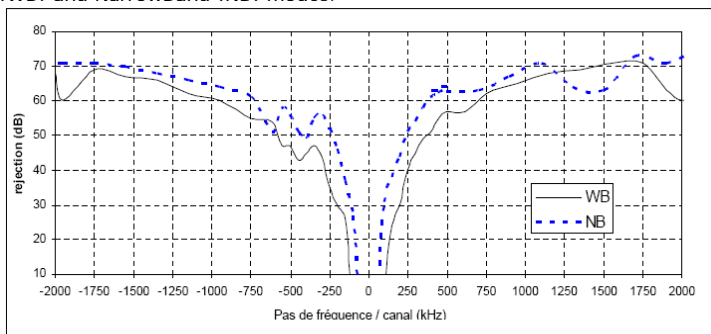

Particular attention is required for product installation. In the case where several links must work in the same area (independently of the channel positions), the minimum distance between 2 ARF43 belonging to different radio links is 3 meters. Even with this precaution (depending of the product environment), channel rejection could be reduced.

RSSI reading

The RSSI (Received Strength Signal Indicator) gives an indication for the received power level on the first channel of the hopping table. It could be accessed with `ATS230?<cr>` command.

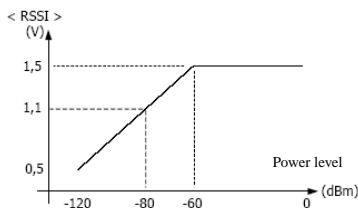

NOTES

The RSSI level is only an indication. Use this level with care due to the dispersion between components.

The schema above could be modified from one to another product. The operating temperature could also have an impact on these dispersions.

The RSSI level could also indicate the potential presence of any jammer in the used channel.

The RSSI is a necessary but not sufficient condition to get a correct reception.

Antenna versions

Integrated antenna, IP 65 casing

External antenna, through 500 mm of RG58C cable + TNC connector. The IP65 modem casing is conserved and the external antenna is compatible with outdoor using.

Modem operating mode

Two operating modes are available:

Command mode (using of AT commands)

Transceiver or normal mode (serial data are transmitted on radio link)

At power-up, the transceiver is in transceiver mode: it is able to send / receive data to / from the radio link according to its current parameters configuration.

Command mode

The command mode is used to read and update the modem configuration registers using AT command.

NOTE

The AT command can be locked using ATPWD command.

In command mode the radio is inhibited (reception and transmission), excepted when using test command.

Entering command mode: issues on the serial link a +++ sequence. The sequence of 3 consecutive + characters is accepted only if no character have been seen before and after the +++ sequence. Register (S214) defines the silence duration.

TIPS 1

If you are using a terminal (such as Hyperterm), you have to send the +++ sequence using a text file (first create a text file containing only the +++ characters, and then use in Hyperterm the command "Send text file" in the "Transfer menu")

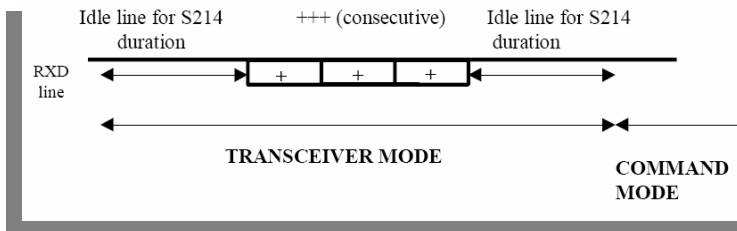
TIPS 2

Exiting command mode (return back in transceiver mode): send the serial command

ATO <cr>

Command mode using USB: Caution, the USB link can not guaranteed the timing requested for the +++ sequence. Therefore entering command mode could fail in such a case.

EASY CHECK

When receiving a right command, modem will answer:

'O'<cr> (ASCII character 0x4F) for accepted command (or OK command)

'E'<cr> for error

Specific string when specified

Transceiver mode

In transceiver mode two protocols are available:

Transparent mode, without flow control. When transmitting, data received from the serial link are transmitted on the radio link. When data are received on the radio link, these data are sent on the serial link.

Addressed mode, with flow control (see register S216)

The communication is always half-duplex. The radio transmission is processed prior to the radio reception (when the transceiver is sending a radio frame, it is not able to decode any incoming radio frame).

If no data are sent on the serial link, the modem is waiting for radio reception. Each radio frame sent by another modem is received and the validated data extracted from the radio frame are sent on the serial link.

All the data received on the serial link are encapsulated in a radio frame.

The radio frame format depends of the used protocol.

When acting as transceiver, the radio frame transmission always start on the following conditions:

Detection of a silence on the serial link (greater than S217) after the reception of the latest character.

Or when the number of received characters from the serial link is longer or equal to the maximum radio frame size (S218).

Transmission mode using USB: Caution, the data transmission integrity can not be guaranteed because it involves usb hardware, several software layers and the use of an usb/serial gateway. It is strongly recommended to remove hub and other usb devices from the bus to ensure correct modem operations.

Transparent mode

In transparent mode, the modem acts as a wire serial link. It means that alternately, the modem sends on the radio the data received from the serial link and sends on the serial link the data received from the radio.

The radio frame format is :

<Preamble><synchro>DATA <postamble>.
 Preamble, synchronisation and postamble are used for the radio reception.

Addressed mode

In transmission mode, data received on the serial link are sent on the radio link with the following format:

<Preamble><synchro><Address> DATA <postamble>.
 Preamble, synchronisation and postamble are used for the radio reception.
 The Address field is set up with S256 value (LSB first).

In reception mode : The <Address> field of the radio frame is checked with the reception address (S252)

If the radio frame address matches with the transceiver reception address (S252), DATA (and only DATA) are transmitted on the serial link otherwise received data are silently discard

Set of commands

AT commands are interpreted only when the transceiver is in command mode.

Command: are used to read and update the modem parameters

A command starts with the 2 ASCII 'AT' characters. 'AT' means 'Attention' follow with one or several characters or other data.

Each command is ended with <cr> (carriage return).

In the same command, the time between 2 characters must be less than 10s.

EASY CHECK

When receiving a right command, modem will answer:

'O'<cr> (ASCII character 0x4F) for accepted command (or OK command)

'E'<cr> for error

Specific string when specified

Set of commands

Commands	Description
<i>Operating mode selection</i>	
ATO	Return back to transceiver mode.
<silence>+++<silence> >	Command mode activation. The +++ sequence must be preceded and followed by a calibrated silence (no other character)
<i>Registers management</i>	
ATSn?	Display the Sn register content where n represents the register number. The response has the following format: Sn=y<cr><lf>
ATSn=m	Set the Sn register value with 'm'. n represent the register number..
AT&W	Save the new register configuration in EEPROM. Each time you switch on the modem, the EEPROM configuration will be loaded in the modem registers.
AT/S	Display all registers value. The response has the following format: Sxxx=y<cr><lf> for each registers.
AT/V	Software version display. The response has the following format: Adeunis RF: ARF43 Vxx.yy<cr><lf>
ATR	Restore the registers default values
ATPWD=m	m = pin code (register S205) : unlock all AT commands. m = 0000 : set registers to default value and unlock all AT commands.
<i>Test modes</i>	
ATT1	Pure Carrier (data=0) transmission using current channel. The output of this mode is achieved by reception of any character on the serial link.
Commands	Description
ATT2	Pure Carrier (data=1) transmission using current channel. The output of this mode is achieved by reception of any character on the serial link.

ATT3-ATT6	Modulation using current channel. The output of this mode is achieved by reception of any character on the serial link. ATT3: 0.9 kHz modulation ATT4: 3.6 kHz modulation ATT5: 14.4 kHz modulation ATT6: 28.8 kHz modulation
-----------	--

AT/S is not available for baud rate lower than 2400 bauds

Register description

The register value could be updated using the `ATSn=m<cr>` command and displayed using `ATSn?<cr>` command.

At power-up, the previous transceiver configuration is restored from E2PROM (non-volatile) to RAM. The registers are located in RAM registers, any modification is performed on RAM registers: To save current register configurations, it is necessary to use the `AT&W<cr>` command (If not, the updated parameters are lost in case of power shortage).

The registers are divided in 2 types: read only (R) or read/write (R/W)

Type	Register	Function	Description	Default value	Note
<i><u>Radio management</u></i>					
R/W	S200	Channel number	Radio channel for 868 / 870 MHz version : From '0' up to '13', Wide Band channel. From '14' up to '83', Narrow Band channel.	1	3
R/W	S201	Radio rate (for wide band only)	Wide band radio rate selection 0: 57 600 bit/s (recommended) 1: 38 400 bit/s	0	2,3

Type	Register	Function	Description	Default value	Note
R/W	S202	Command mode, auto-exit	Automatic command mode exit 0 : (no specific management), the command mode will be exited only when an ATO command is issued. From 1 to 60 : timeout in second. ➔ If no activity (no character, command reception) is detected in command mode for the programmed timeout, the command mode will be exited. The module is back to transceiver mode	0	
R/W	S204	Preamble duration	Preamble duration, unit ms From 3 up to 50	3	4
R/W	S217	Serial timeout for radio	Serial timeout before starting radio transmission, unit ms. From 3 up to 240.	3	1
R/W	S218	Radio frame length	Size of the radio frame (from 1 up to 240). When this size is reached: the transceiver sends a radio frame The RTS signal is activated (pull to VDD) only if the module is operating in the addressed mode.	128	
R	S230	RSSI level	Displays the reception level of the latest received message. Response: S230=-xxx dBm<cr><lf> with xxx decimal value The RSSI values range from -115 up to -60 dBm.	None	

Type	Register	Function	Description	Default value	Note
R/W	S231	RF OUT level	Adjusts the RF out level 868 / 870 MHz version : 0 => 10 dBm (10 mW) 1 => 14 dBm (25 mW) 2 => 17 dBm (50 mW)	2	
<i>Serial link</i>					
R/W	S210	Baudrate	Serial link rate in bits/s '0': 600 '1': 1 200 '2': 2 400 '3': 4 800 '4': 9 600 '5': 19 200 '6': 38 400 '7': 57 600 '8': 115 200	4	1,2,6
R/W	S211	Data length	'7' : 7 bits '8' : 8 bits	8	6
R/W	S212	Parity	'1' : none '2' : even '3' : odd	1	6
R/W	S213	Stop bits	'1' : 1 stop bit '2' : 2 stop bit	1	6
R/W	S214	Command timeout	Time out duration for detecting the +++ pattern, unit ms. From 3 up to 240.	3	1
R/W	S215	Interface type	'0' : RS232 only '1' : RS232 or RS485 (managed DE/RE lines)	1	
R/W	S216	Handshake	'0' : hardware, RTS (restricted to addressed protocol) '2' : none	2	
R/W	S219	RS485 delay	Delay between DE activation and the first RS485 transmitted byte From 0 up to 160	3	

Type	Register	Function	Description	Default value	Note
<i>Protocol</i>					
R/W	S220	Protocol	'1' = transparent mode '6' = addressed	6	
R/W	S252	Reception address	From 0 up to FFFF Used in addressed protocol only, for filtering incoming frame		
R/W	S256	Transmission address	From 0 up to FFFF Used in addressed protocol only, added to outgoing frame		
<i>Miscellaneous</i>					
R/W	S205	Pin code	Pin code value Value 0000 is not allowed	1111	
R/W	S207	Pin code activation	0 pin code disabled 1 pin code enabled	0	

NOTE 1

When a serial speed change is requested, the S214 and S217 registers values are automatically set to a value greater or equal than the duration of three characters in the requested speed (13 ms for 2400 bauds, 7 ms for 4800, 3 ms otherwise).

NOTE 2

Streaming mode without flow control. Be careful → using a serial rate greater to the radio rate must produce characters lost if the flow control is not used.

If the radio rate is equal to the serial rate, the radio frame is longer than the serial frame, due to radio protocol overhead; but the radio overhead will be generated only when the radio transmission begins → this overhead will be absorbed by internal buffer size.

For example, if the current radio rate is 57 600 kbit/s, a serial rate of 57 600 should be used without flow control, while using a serial rate of 115 200 (with 57 600 for the radio rate) will produce data overrun.

For avoiding characters lost, you should:

Use the flow control (addressed mode with hardware handshake)

or use a serial rate lower or equal to the radio rate

or limit the size of serial data to the maximum size of the internal buffer (S218).

NOTE 3

(S200 register) see chapter [Radio channels](#) and [Channel adjustment](#)

NOTE 4

The preamble duration is linked to the current radio rate. For high speed radio rate (Wide Band) the preamble duration is adjusted to 3ms while for low speed rate (Narrow Band) the preamble duration is adjusted to 6ms.

The minimum preamble values are:

	Minimum preamble value
WB channel (high radio rate)	3 ms
NB channel (low radio rate)	6 ms

In NB configuration the S204 register value could be set to a value lower than 6ms. In this case, the module prevents using this incorrect preamble length with an automatic adjustment to 6ms.

NOTE 5

(S252 register) see chapter [Low power mode](#)

NOTE 6

When changing the serial link configuration (rate, parity, stop bit...), the answer is done using the old serial link format, the next command must be sent using the new serial format.

Specifications

General technical characteristics

	868 / 870 MHz version
Operating temperature	-20 to +70 °C
Power supply	8 to 32 Volts
Size	145x100x40 mm
Number of channels	14 channels in WB and 70 channels in NB
Modulation	FSK
Packaging	IP65 Box with integrated or remote antenna

Transmitter

	868 / 870 MHz version
Programmable Frequencies	868 to 870 MHz (863 to 870 MHz band in progress, see page 7)
Programmable Radiated RF power	Up to 17 dBm (50 mW).
Tx / Rx consumption	0,5 W / 0,25 W

Receipt

	868 / 870 MHz version
Receiver Sensitivity	Down to -105 dBm for BER 10-3
Radio data rate	from 9600 up to 57600 bps
RSSI	available through AT commands

Protocol

Serial data rate	868 / 870 MHz version from 600 to 115200 bauds (programmable through AT commands)
Serial ports	TxD, RxD, RTS, CTS. Standard configuration : RS232 port. The RS485 configuration is performed through AT commands
Setup and configuration	through Hayes commands
Modes	Transparent or Addressed mode, full custom firmware on demand
Embedded protocol	ADEUNIS-RF enhanced and versatile RF communications manager
Embedded profiles	Multimode modem
Standards compliance	EN 300-220 and EN 301-489 (full certified modem)
Range	up to 1000m

References

ARF7263E : Modem RS232/RS485 – IP65 box

ARF7263G : Modem RS232/485- IP65 box with external antenna(*)

ARF7263F : Modem USB – IP65 box

ARF7263H : Modem USB –IP65 box with external antenna(*)

(*) using RG58C cable and TNC Fem connector

Firmware update

Firmware	Updates
V1.03	Pin code added
V1.02	Radio calibration optimization
V1.01	RS485 management enhancement
V1.00	S205 register added S210 600 and 1200 bps added S215 change default register value to 1 Create the 915 MHz version optimized for FCC Part 15.247 : S200 : 25 channel for 915MHz
V0.08 / V0.09	S202 register added S204, preamble duration → the minimum preamble duration is 3ms for the radio rate 57 Kbit/s and 6ms for the 9.6 kbit/s
Document	Updates
07-08-V16	Voltage correction
07-08-V15	Pin code added
12-07-V14	S232 description deleted (Low power mode)
12-07-V13	Radio calibration duration worst cases is 90ms
10-07-V12	"EASY CHECK" assertions + DC IN & Consumption new specs
10-07-V11	Datasheet is 868Mhz specific (915Mhz not covered)
06-09-V10	Minor fixes, USB recommendation
06-07-V9	SW1.1 for enabling the RS485 interface + SW1.2 for resistor activation