

Model 485TBLED RS-232 to RS-485 Converter CE

The 485TBLED converts unbalanced, full-duplex RS-232 signals to balanced, full or half-duplex RS-422 or RS-485 signals. RS-485 is an enhanced version of the RS-422 Standard. It allows multiple drivers and receivers on a two-wire or four-wire system.

The RS-232 port, configured as a DCE port, has a female DB25 connector with pins 2 (TD input), 3 (RD output), and 7 (Signal Ground) supported. Pins 4 (RTS) and 5 (CTS) are tied together, and pins 6 (DSR), 8 (CD), and 20 (DTR) are also tied together. Pins 1 (Frame Ground) and 7 (Signal Ground) are connected straight through to the RS-485 terminal blocks. The RS-485 terminal blocks support Transmit Data (A-) and (B+), Receive Data (A-) and (B+), Frame Ground, Signal Ground, and +12 VDC input. See Schematic.

LEDs

The 485TBLED has two LEDs: a Transmit Data LED to show when the RS-485 driver is enabled and a Receive Data LED showing data appearing at pin 3 of the RS-232 port. These are very useful for determining if data is getting through the converter. Note that the TD LED indicates that the RS-485 driver is enabled. Data must be present on pin 2 of the RS-232 side for data to be transmitted out of the RS-485 side. If no data is present, no data will be transmitted even though the TD LED is illuminated.

Flow Control

The 485TBLED uses two different methods to enable the RS-485 driver, either by toggling Request to Send (pin 4) of the RS-232 side, or by automatic sensing of the data on Transmit Data (pin 2) of the RS-232 side. This option is user selectable by setting push-on jumpers located next to the terminal blocks. See Fig. 1. Removing both sets of jumpers completely can also constantly enable the RS-485 driver and receiver. This makes the 485TBLED act like an RS-422 converter.

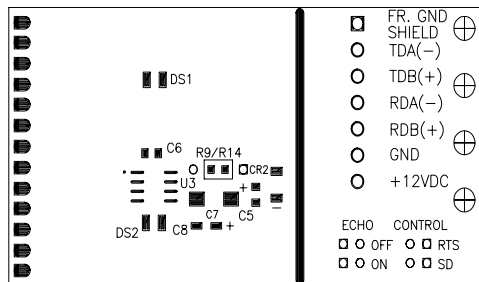

Figure 1

Baud Rate

There is a timing component on the converter, a resistor **R9**, see Fig. 1. This component is part of the automatic sensing circuit, and affects the baud rate at which the converter can be used in a two-wire setup. This component, is factory selected to allow the converter to run at 9600 baud or higher. With this component, the RS-485 driver will shut off approximately 1ms after the last character has been sent. If you need to change the 485TBLED to a baud rate other than 9600 baud, you can change this component. To change the baud rate, remove **R9** and add through hole component **R14**, see Table 1.

Figure 2 shows how to interconnect two RS-485 converters using 4-Wire and 2- Wires.

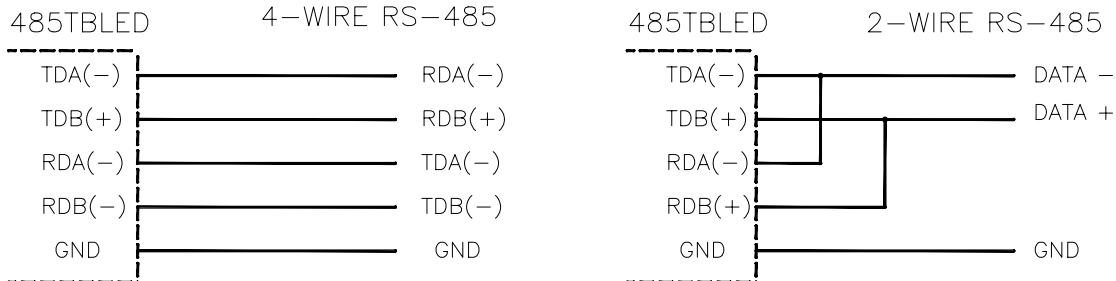

Figure 2

International Headquarters:
B&B Electronics Mfg. Co.

B&B Electronics Ltd

Delmation Products BV
T +31 (0)79 342 2041
info@delmation.nl
www.delmation.nl

The Echo jumper is used in the two-wire mode, and allows you to prevent data being sent from the RS-232 port from being echoed back to the RS-232 port. Up to 32 receivers can be driven by any one RS-485 driver, allowing you to put together large systems with many drop points. If you are using termination resistors, they should be located at opposite ends of the system.

Proper operation of any RS-485 system requires the presence of a return path. The RS-485 Standard recommends that a third wire be used for this. For safety, a 100 ohm resistor should be connected between Signal Ground and the "reference wire" at every drop point. While it may be possible to interconnect Signal Grounds directly, this is not recommended due to the danger of circulating currents possibly being present.

No wire type or maximum run length is listed in the RS-485 Standard. However, the RS-422 Standard (which is very similar) recommends number 24AWG twisted pair telephone cable with a shunt capacitance of 16 picofarads per foot, and no more than 4000 feet of distance.

Specifications: Dimensions: 2.14" x 3.32" x .725" (54.5 x 84.34 x 18.43mm)
 Supply Voltage: 9 – 14 Vdc Temperature Range: 0° C – 70° C
 Data Rate: Up to 115.2 kbps Connector: DB25 Female on RS-232 side

Table 1		
Resistor Replacement For Changing Baud Rate Timeouts		
Baud Rate	Time (ms)	Resistor R9/R14 (ohm)
1200	8.33	820K
2400	4.16	430K
4800	2.08	200K
9600	1.04	100K
19200	.520	56K
38400	.260	27K
57600	.176	16K
115200	.0868	8.2K

DECLARATION OF CONFORMITY

Manufacturer's Name: B&B Electronics Manufacturing Company
 Manufacturer's Address: P.O. Box 1040
 707 Dayton Road
 Ottawa, IL 61350 USA
 Model Number: 485TBLED
 Description: RS-232 to RS-485 Converter
 Type: Light industrial ITE equipment
 Application of Council Directive: 89/336/EEC
 Standards: EN 55022
 EN 61000-6-1
 EN 61000 (-4-2, -4-3, -4-4, -4-5, -4-6, -4-8, -4-11)



 William H. Franklin III, Director of Engineering



International Headquarters:
B&B Electronics Mfg. Co.

B&B Electronics Ltd

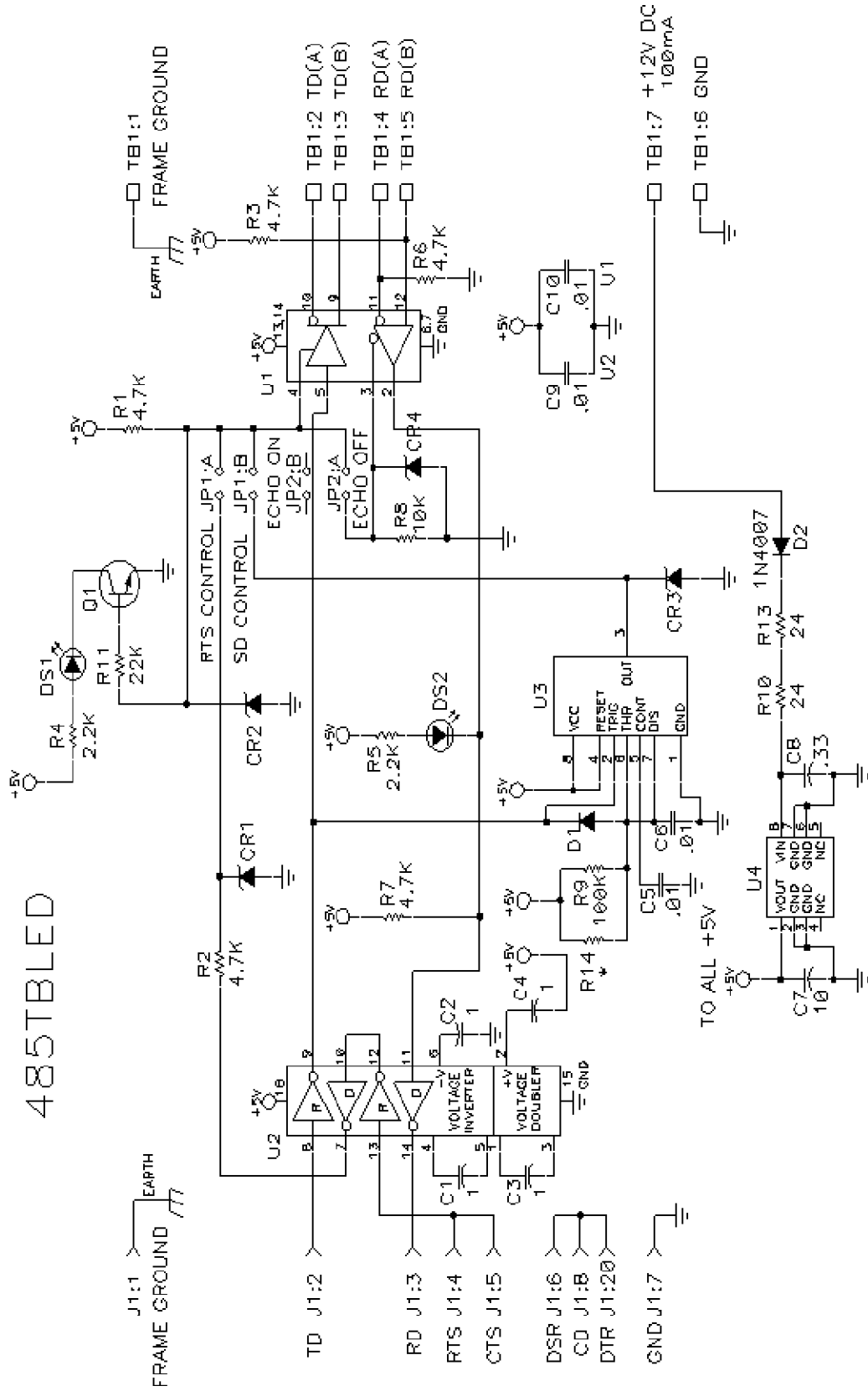
Delmation Products BV
 T +31 (0)79 342 2041
 info@delmation.nl
 www.delmation.nl



JLB

International Headquarters:
B&B Electronics Mfg. Co.

B&B Electronics Ltd

Delmation Products BV
 T +31 (0)79 342 2041
 info@delmation.nl
 www.delmation.nl