



Model: 485OPDR
Industrial DIN Rail Mounted
RS-422/485 Line Isolator/Repeater CE

Introduction

The 485OPDR can be used to optically isolate one piece of RS-422/485 equipment from the rest of an RS-422/485 system, or one local group of RS-422/485 equipment from another. It can also be used as an RS-422/485 repeater. This allows the user to expand an existing RS-485 system to greater than the 32 node limitation in the RS-485 Standard. A typical setup using the 485OPDR as an RS-485 repeater is shown in Figure 3.

All data lines as well as power and ground are isolated from one side of the 485OPDR to the other. The 485OPDR uses terminal blocks on each side of the device and supports Transmit Data (A) and (B), Receive Data (A) and (B), Signal Ground, and Protective Ground on the line side. Switch positions are the same for each side of the 485OPDR e.g. switch position 3 on both switches is 9600 baud.

Connection

The 485OPDR can operate in: two-wire half-duplex systems, four-wire half-duplex, or full-duplex systems (see Figures 1 and 2). The 485OPDR can also operate as a four-wire to two-wire converter (Figure 2). By connecting one side of the 485OPDR as a two-wire device and one side as a four-wire device, equipment meant for a point-to-point RS-422 interface can be connected directly to an RS-485 two-wire multi-drop system.

For the transient suppression of the 485OPDR to work properly, the protective ground (PG) terminal must be tied to a good frame (chassis, green wire, or earth) ground. The RS-422/485 Application Note explains how to use termination resistance and how to ground RS-422/485 systems. It is available on B&B's web site www-bb-elec.com or one can be mailed to you free of charge.

RS-485 Operation

When no data is being transmitted through the 485OPDR, the receivers are enabled on both sides of the device. As data is received on one side of the 485OPDR, the opposite driver is enabled. When the 485OPDR receives the falling edge of the last data bit, it waits one character time to disable the driver. This timeout period is factory preset for about one millisecond to accommodate a baud rate of 9,600 bits per second. The timeout period can be selected by dipswitch, accessible from outside the unit. The preset baud rate dipswitch settings available on the 485OPDR should accommodate most systems. Alternative time-outs, can be achieved by turning the baud rate dipswitches OFF and placing a specific value through-hole resistor (R7 & R28) and/or through-hole capacitor (C8 & C12), on the board inside the unit near the switches. Through-hole resistor values for standard baud rate time out periods are given in Table 1. Setting non-standard baud rates may require a capacitor change. The 485OPDR is factory set in two-wire mode (switch 7 & 8 are ON) at a 9600 baud rate, (switch 3 is ON), (up = ON).

Specifications

Isolation:	2,000 volts RMS for 1 minute optical isolation of data lines.
Surge Suppression:	6.5V working peak voltage, bi-directional over voltage suppressor 600W peak power dissipation. 3,000 pF maximum capacitance.
Data Rates:	Switch selectable for 2400 to 115.2K baud For other baud rates up to 460.8K see Table 1.
Temperature Rating:	-40 to +80°C (-40 to +176°F)
Humidity Rating:	0 to 95% non-condensing
Power Requirements:	+10 to 30V (dissipates 800mW max)
Current Draw:	67mA @ 12VDC
Dimensions:	3.9L x 2.9W x 0.92H in (10.0 x 7.4 x 2.3 cm)

DECLARATION OF CONFORMITY

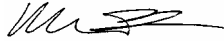
Manufacturer's Name:	B&B Electronics Manufacturing Company
Manufacturer's Address:	P.O. Box 1040 707 Dayton Road Ottawa, IL 61350 USA
Model Numbers:	485OPDR
Description:	DIN Mount RS-422/485 Opt. Isolated Repeater
Type:	Light industrial ITE equipment
Application of Council Directive:	89/336/EEC
Standards:	EN 55022 EN 61000-6-1 EN 61000 (-4-2, -4-3, -4-4, -4-5, -4-6, -4-8, -4-11)
 William H. Franklin III, Director of Engineering	
CE	

International Headquarters:

B&B Electronics Mfg. Co. 707 Dayton Road P.O. Box 1040 Ottawa, IL 61350 USA
815-433-5100 Fax 433-5104 www.bb-elec.com orders@bb-elec.com support@bb-elec.com

B&B Electronics Ltd Westlink Commercial Park Oranmore Co. Galway Ireland
+353 91 792444 Fax +353 91 792445 www.bb-europe.com orders@bb-elec.com support@bb-europe.com

Table 1. Baud Rate Selection

	Position 1	Position 2	Position 3	Position 4	Position 5	Position 6	R7 & R28	Time (ms)
1200	OFF	OFF	OFF	OFF	OFF	OFF	820kΩ	9.02
2400	ON	OFF	OFF	OFF	OFF	OFF	Not Used	4.73
4800	OFF	ON	OFF	OFF	OFF	OFF	Not Used	2.20
9600	OFF	OFF	ON	OFF	OFF	OFF	Not Used	1.10
19200	OFF	OFF	OFF	ON	OFF	OFF	Not Used	.62
38400	OFF	OFF	OFF	OFF	ON	OFF	Not Used	.29
57600	OFF	OFF	OFF	OFF	OFF	ON	Not Used	.17
76800	ON	OFF	ON	ON	OFF	OFF	Not Used	.15
115200	ON	ON	ON	OFF	OFF	OFF	Not Used	.11
153600	OFF	OFF	OFF	OFF	OFF	OFF	6.2kΩ	.07
230400	OFF	OFF	OFF	OFF	OFF	OFF	4.3kΩ	.05
460800	OFF	OFF	OFF	OFF	OFF	OFF	2kΩ	.02

Table 2. Typical Setups

	Position 8 RX Enable	Position 7 TX Enable
RS-485 2-Wire Mode (half duplex)	ON	ON
RS-485 4-Wire Mode (full duplex)	OFF	ON
RS-422 Mode (full duplex)	OFF	OFF

LEDs

The red LEDs indicate when data is transferred to the RS-485 driver. The LED with the arrow pointing to the J2 terminals, A – F, is LED DS2. It indicates that data is being transmitted out of J2. The LED with the arrow pointing to the J1 terminals, G – M, is LED DS1. This LED indicates data is being transmitted out of J1.

FIG. 1 FOUR WIRE SETUP

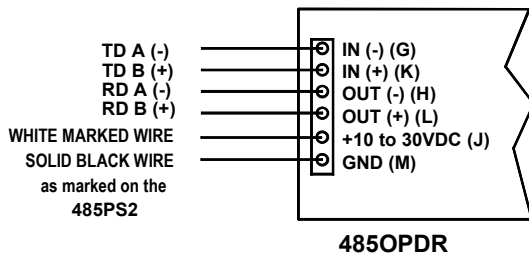

FIG. 2 485OPDR AS A FOUR WIRE TO TWO WIRE CONVERTER

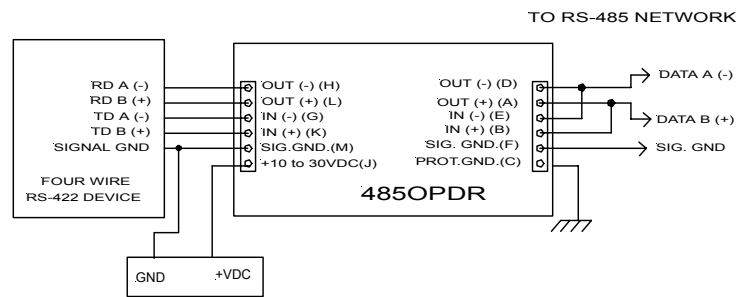
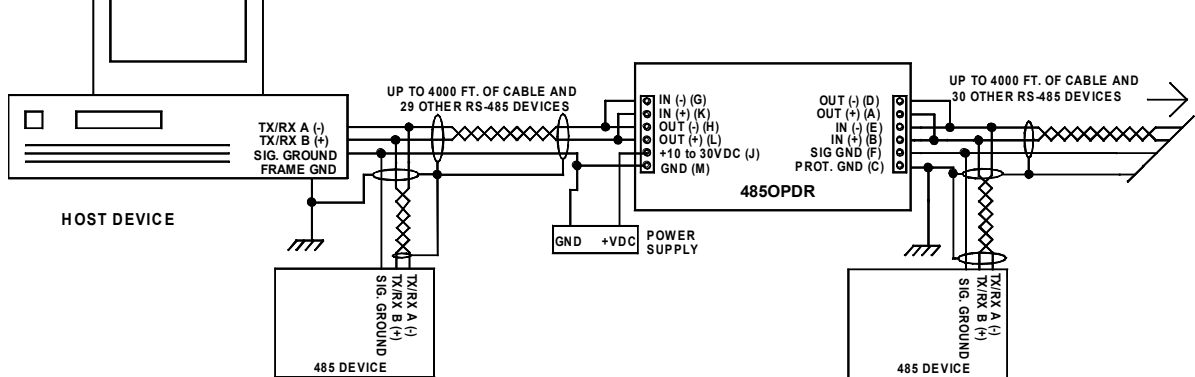

FIG. 3 485OPDR AS A TWO WIRE RS-485 REPEATER



International Headquarters:

B&B Electronics Mfg. Co. 707 Dayton Road P.O. Box 1040 Ottawa, IL 61350 USA
815-433-5100 Fax 433-5104 www.bb-elec.com orders@bb-elec.com support@bb-elec.com

B&B Electronics Ltd Westlink Commercial Park Oranmore Co. Galway Ireland
+353 91 792444 Fax +353 91 792445 www.bb-europe.com orders@bb-elec.com support@bb-europe.com

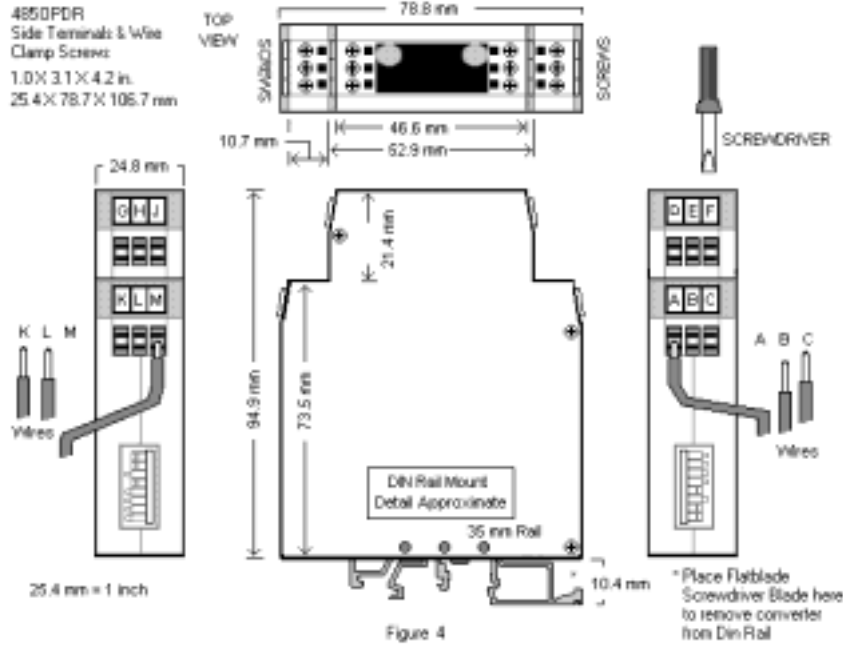
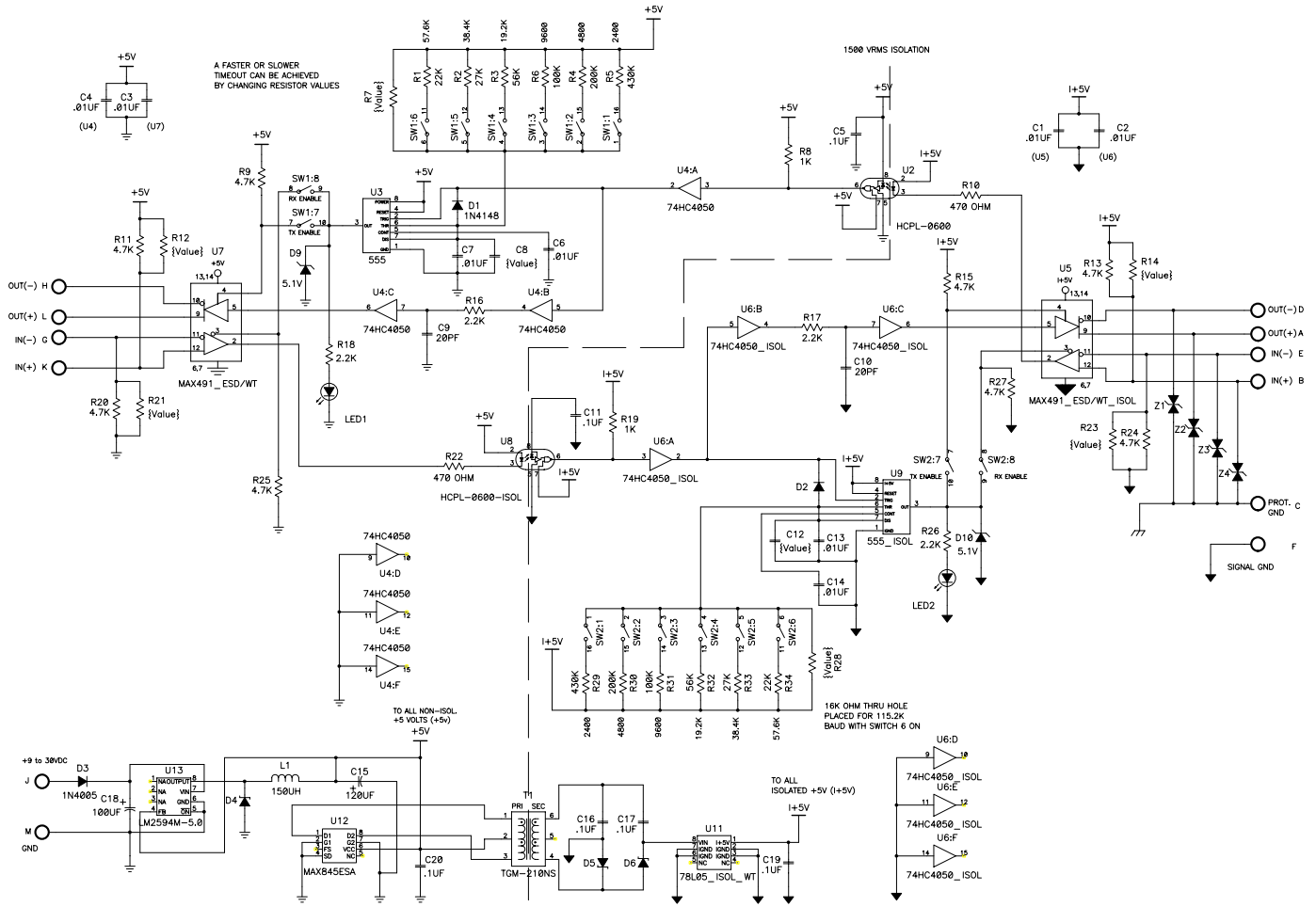

Figure 4



International Headquarters:

B&B Electronics Mfg. Co. 707 Dayton Road P.O. Box 1040 Ottawa, IL 61350 USA
815-433-5100 Fax 433-5104 www.bb-elec.com orders@bb-elec.com support@bb-elec.com

B&B Electronics Ltd Westlink Commercial Park Oranmore Co. Galway Ireland
+353 91 792444 Fax +353 91 792445 www.bb-europe.com orders@bb-elec.com support@bb-europe.com