

SCM5B392



Matched-Pair Servo/Motor Controller Modules

Description

The SCM5B392 servo/motor controller module set is designed to solve the problem of extending a servo or motor controller signal a long distance with the possibility for noise pickup and/or contacting hazardous voltages. Each SCM5B392 module set is made up of two modules: a voltage input/current output module and a current input/voltage output module (Figure 1).

The voltage input module connects to the servo or motor controller voltage output and provides an isolated 4 to 20mA output which connects to the input of the current input module. The current input module isolates and provides an output voltage identical to that of the servo or motor controller. Thus the original control signal has been isolated (twice) and extended via a 4 to 20mA current loop.

Several mounting options are available for the SCM5B392 module set. If a large number of channels are required, the SCMPB01 16 channel backpanel and SCMPB05 8 channel backpanel are available. Smaller channel numbers can be accommodated with the SCMPB03 single channel mounting panel and SCMPB04 dual channel mounting panel. These can be mounted on a DIN rail.

► Features

- Extends the Distance and Isolates Servo/Motor Controller Signals
- Provides Isolated Current Loop Interface Between Controller and Motor or Actuator
- Accepts High Level Voltage Inputs up to $\pm 10V$
- Provides High Level Voltage Outputs up to $\pm 10V$
- 1500Vrms Transformer Isolation (3000Vrms Total Loop)
- ANSI/IEEE C37.90.1 Transient Protection
- Current Loop is Protected to 240VAC Continuous
- 1kHz Signal Bandwidth
- 100dB CMR
- $\pm 0.06\%$ Total Loop Accuracy
- $\pm 0.01\%$ Total Loop Linearity
- CSA Certified, FM Approved, CE and ATEX Compliant

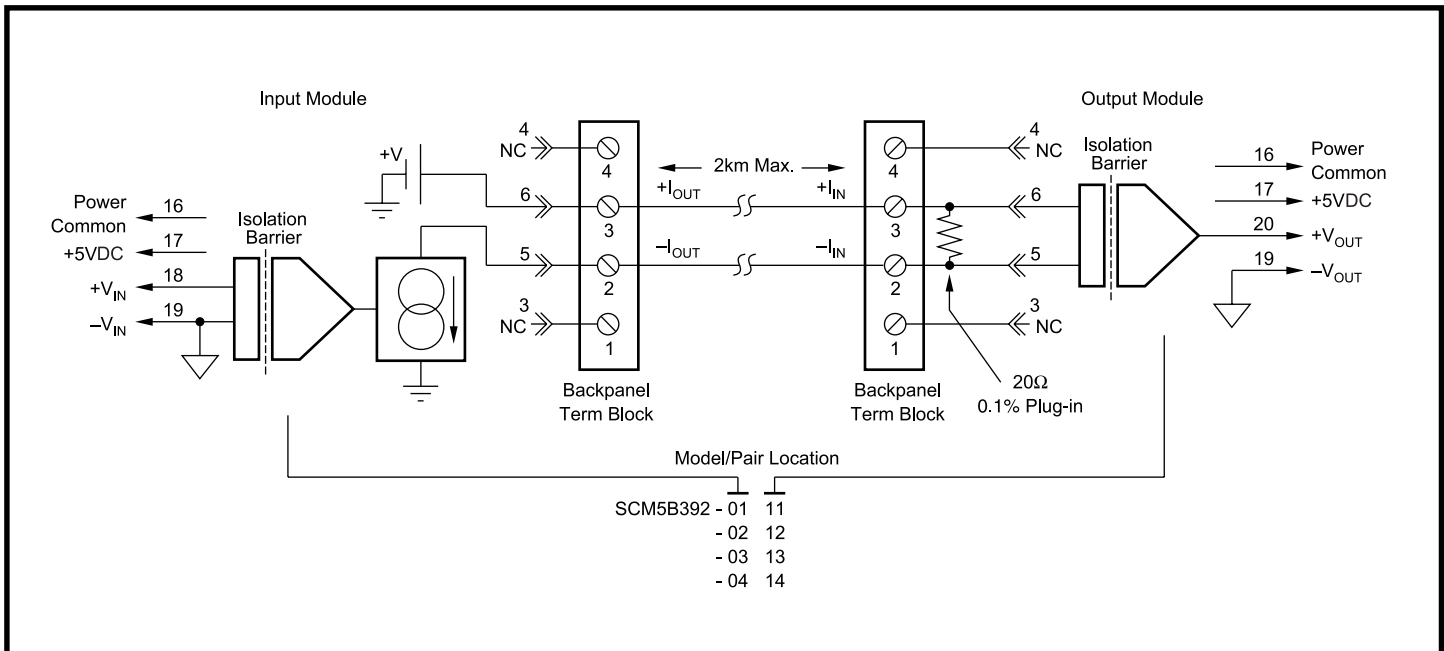

Figure 1: SCM5B392 Block Diagram

Specifications Typical at $T_A = +25^\circ\text{C}$ and +5V power

Module	SCM5B392-01,-02,-03,-04 (Input)	SCM5B392-11,-12,-13,-14 (Output)
Input Range	See Ordering Information	4mA to 20mA
Input Resistance	50M Ω (-01,-02) 2M Ω (-03,-04)	20 Ω
Accuracy	N/A	$\pm 0.1\%$
Stability	N/A	$\pm 10\text{ppm}/^\circ\text{C}$
Input Protection		
Continuous	$\pm 36\text{V}$ (no damage)	240Vrms max
Transient	N/A	ANSI/IEEE C37.90.1
Output Range	4mA to 20mA	See Ordering Information
Over Range Capability	10%	N/A
Output Compliance Voltage (Open Circuit)	22VDC	N/A
Loop Resistance Range	0 to 600 Ω (0 to 700 Ω for Power Supply Voltage greater than 4.95VDC)	N/A
Output Resistance	N/A	50 Ω
Output Selection Time (to $\pm 1\text{mV}$ of V_{OUT})	N/A	6 μs at $C_{\text{load}} = 0$ to 2000pF
Output Current Limit	26mA	+8mA
Output Protection		
Continuous	240Vrms max	Short to Ground
Transient	ANSI/IEEE C37.90.1	N/A
CMV		
Continuous	1500Vrms max, output to input	*
Transient	ANSI/IEEE C37.90.1	*
CMR (50Hz or 60Hz)	100dB	*
NMR (-3dB at 1KHz)	80dB per Decade above 1kHz	120dB per Decade above 1kHz
Accuracy	$\pm 0.03\%$ Span	*
Nonlinearity	$\pm 0.005\%$ Span	*
Stability		
Zero	$\pm 0.5\mu\text{A}/^\circ\text{C}$	$\pm 50\mu\text{V}/^\circ\text{C}$
Span	$\pm 20\text{ppm}/^\circ\text{C}$	$\pm 25\text{ppm}/^\circ\text{C}$
Noise		
Output, 100kHz	10 μA p-p	200 μV rms
Bandwidth, -3dB	1kHz	1kHz
Rise Time, 10 to 90% Span	340 μs	750 μs
Sample and Hold		
Output Droop Rate	40 $\mu\text{A}/\text{s}$	N/A
Acquisition Time	50 μs	N/A
Enable Control		
Max Logic "0"	+0.8V	*
Min Logic "1"	+2.4V	*
Max Logic "1"	+36V	*
Input Current "0"	0.5 μA	*
Power Supply Voltage	+5VDC $\pm 5\%$	*
Power Supply Current	170mA	30mA
Power Supply Sensitivity	$\pm 0.5\mu\text{A}/\%$ typ	$\pm 20\mu\text{V}/\%$ RTI
Mechanical Dimensions (h)(w)(d)	2.28" x 2.26" x 0.6" (58mm x 57mm x 15mm)	*
Environmental		
Operating Temp. Range	-40 $^\circ\text{C}$ to +85 $^\circ\text{C}$	*
ATEX Group II, Category 3	-20 $^\circ\text{C}$ to +40 $^\circ\text{C}$	*
Storage Temp. Range	-40 $^\circ\text{C}$ to +85 $^\circ\text{C}$	*
Relative Humidity	0 to 95% Noncondensing	*
Emissions EN61000-6-4	ISM, Group 1	*
Radiated, Conducted	Class A	*
Immunity EN61000-6-2	ISM, Group 1	*
RF	Performance A $\pm 0.5\%$ Span Error	*
ESD, EFT, Surge, Voltage Dips	Performance B	*

Ordering Information (for module pairs)

Model	Input Range	Interface	Output Range
SCM5B392-0111	0V to +5V	4mA to 20mA	0V to +5V
SCM5B392-0212	-5V to +5V	4mA to 20mA	-5V to +5V
SCM5B392-0313	0V to +10V	4mA to 20mA	0V to +10V
SCM5B392-0414	-10V to +10V	4mA to 20mA	-10V to +10V

Ordering Information (for single modules)

Model	Input Range	Output Range	Bandwidth
SCM5B392-01	0V to +5V	4mA to 20mA	1kHz
SCM5B392-02	$\pm 5\text{V}$	4mA to 20mA	1kHz
SCM5B392-03	0V to +10V	4mA to 20mA	1kHz
SCM5B392-04	$\pm 10\text{V}$	4mA to 20mA	1kHz
SCM5B392-11	4mA to 20mA	0V to +5V	1kHz
SCM5B392-12	4mA to 20mA	$\pm 5\text{V}$	1kHz
SCM5B392-13	4mA to 20mA	0V to +10V	1kHz
SCM5B392-14	4mA to 20mA	$\pm 10\text{V}$	1kHz