

8B36

Potentiometer Input Modules

Description

8B modules are an optimal solution for monitoring real-world process signals and providing high level signals to a data acquisition system. Each 8B36 input module isolates, filters and amplifies a single channel of potentiometer input and provides an analog voltage output.

Excitation for the potentiometer is provided by using two matched current sources. When using a 3-wire connection, this method allows equal currents to flow through the sensor leads, cancelling the effects of lead resistances. The excitation currents are small (equal or less than 0.25mA) which minimizes self-heating of the potentiometer.

Signal filtering is accomplished with a three-pole filter optimized for time and frequency response which provides 70dB of normal-mode-rejection at 60Hz. One pole of this filter is on the field side of the isolation barrier for anti-aliasing, and the other two are on the system side.

A special input circuit on the 8B36 module provides protection against accidental connection of power-line voltages up to 240VAC. Clamp circuits on the I/O and power terminals protect against harmful transients.

The modules are designed for installation in Class I, Division 2 hazardous locations and have a high level of immunity to environmental noise.

► Features

- Interfaces to Potentiometers up to 10,000Ω
- High Level Voltage Output
- 1500Vrms Transformer Isolation
- ANSI/IEEE C37.90.1 Transient Protection
- Input Protected to 240VAC Continuous
- 120dB CMR
- 70dB NMR at 60Hz
- ±0.05% Accuracy
- ±0.02% Linearity
- Low Drift with Ambient Temperature
- UL and CE Certifications Pending
- Mix and Match Module Types on Backpanel

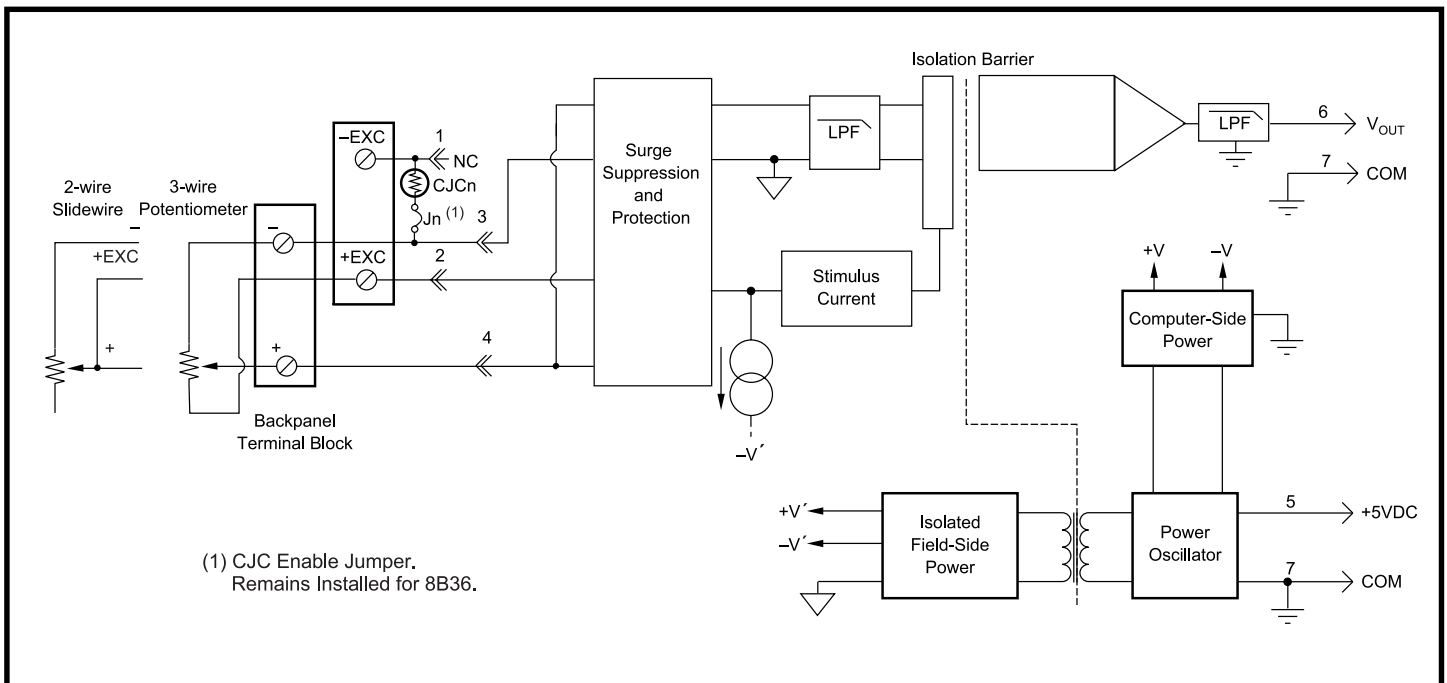

Figure 1: 8B36 Block Diagram

Specifications Typical at $T_A = +25^\circ\text{C}$ and +5V power

Module	8B36
Input Range	0 to 10k Ω
Input Resistance	
Normal	50M Ω
Power Off	200k Ω
Overload	200k Ω
Input Protection	
Continuous ⁽¹⁾	240VAC
Transient	ANSI/IEEE C37.90.1
Sensor Excitation Current	0.25mA; 100 Ω , 500 Ω , 1k Ω Sensor 0.10mA; 10k Ω Sensor
Lead Resistance Effect	$\pm 0.025\Omega/\Omega$; 100 Ω , 500 Ω , 1k Ω Sensor $\pm 0.05\Omega/\Omega$; 10k Ω Sensor
CMV, Input to Output	1500Vrms max
Transient, Input to Output	ANSI/IEEE C37.90.1
CMR (50 or 60Hz)	120dB
NMR	70dB at 60Hz
Accuracy ⁽²⁾	$\pm 0.05\%$ Span
Nonlinearity	$\pm 0.02\%$ Span
Stability	
Output Offset	$\pm 20\text{ppm}/^\circ\text{C}$
Gain	$\pm 50\text{ppm}/^\circ\text{C}$
Noise	
Output, 100kHz	250 μVrms
Bandwidth, -3dB	3Hz
Response Time, 90% Span	150ms
Output Range	0V to +5V
Output Protection	Continuous Short to Ground
Transient	ANSI/IEEE C37.90.1
Power Supply Voltage	+5VDC $\pm 5\%$
Power Supply Current	30mA
Power Supply Sensitivity	$\pm 25\text{ppm}/\%$
Mechanical Dimensions (h)(w)(d)	1.11" x 1.65" x 0.40" (28.1mm x 41.9mm x 10.2mm)
Environmental	
Operating Temp. Range	-40 $^\circ\text{C}$ to +85 $^\circ\text{C}$
Storage Temp. Range	-40 $^\circ\text{C}$ to +85 $^\circ\text{C}$
Relative Humidity	0 to 95% Noncondensing
Emissions EN61000-6-4	ISM, Group 1
Radiated, Conducted	Class A
Immunity EN61000-6-2	ISM, Group 1
RF	Performance A $\pm 0.5\%$ Span Error
ESD, EFT, Surge, Voltage Dips	Performance B

NOTES:

(1) 240VAC between + and - / +EXC / -EXC terminals. 120VAC between - and +EXC / -EXC terminals and between +EXC and -EXC terminals.

(2) Includes nonlinearity, hysteresis and repeatability.

Ordering Information

Model	Input Range	Output Range
8B36-01	0 to 100 Ω	0V to +5V
8B36-02	0 to 500 Ω	0V to +5V
8B36-03	0 to 1k Ω	0V to +5V
8B36-04	0 to 10k Ω	0V to +5V