

# 8B37

## Thermocouple Input Modules

### Description

8B modules are an optimal solution for monitoring real-world process signals and providing high level signals to a data acquisition system. Each 8B37 module isolates, filters and amplifies a single channel of temperature input from a thermocouple input signal and provides an analog voltage output.

The 8B37 can interface to industry standard thermocouple types: J, K, T, R, and S and has an output signal of 0 to +5V. Each module is cold-junction compensated to correct for parasitic thermocouples formed by the thermocouple wire and screw terminals on the mounting backpanel. Upscale open thermocouple detect is provided by an internal pull-up resistor.

Signal filtering is accomplished with a three-pole filter optimized for time and frequency response which provides 70dB of normal-mode-rejection at 60Hz. One pole of this filter is on the field side of the isolation barrier for anti-aliasing, and the other two are on the system side.

A special input circuit on the 8B37 modules provides protection against accidental connection of power-line voltages up to 240VAC. Clamp circuits on the I/O and power terminals protect against harmful transients.

The modules are designed for installation in Class I, Division 2 hazardous locations and have a high level of immunity to environmental noise.

### ► Features

- Interfaces to Types J, K, T, R, and S Thermocouples
- High Level Voltage Output
- 1500Vrms Transformer Isolation
- ANSI/IEEE C37.90.1 Transient Protection
- Input Protected to 240VAC Continuous
- 120dB CMR
- 70dB NMR at 60Hz
- ±0.05% Accuracy
- ±0.02% Linearity
- Low Drift with Ambient Temperature
- Accurate CJC -40°C to +85°C
- UL and CE Certifications Pending
- Mix and Match Module Types on Backpanel

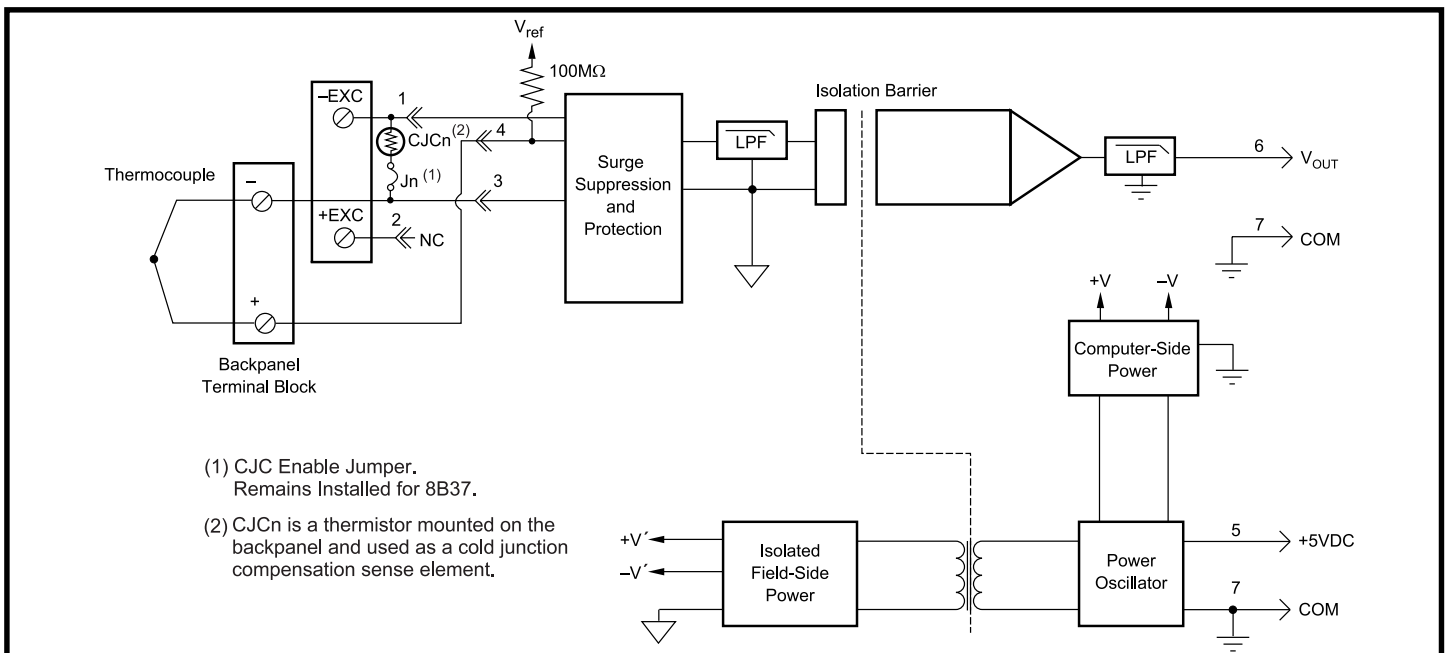

Figure 1: 8B37 Block Diagram

**Specifications** Typical at T<sub>A</sub>=+25°C and +5V power

Module	8B37
Input Range	See Ordering Information
Input Bias Current	-25nA
Input Resistance	
Normal	50MΩ
Power Off	200kΩ
Overload	200kΩ
Input Protection	
Continuous <sup>(1)</sup>	240VAC
Transient	ANSI/IEEE C37.90.1
CMV, Input to Output	1500Vrms max
Transient, Input to Output	ANSI/IEEE C37.90.1
CMR (50Hz or 60Hz)	120dB
NMR	70dB at 60Hz
Accuracy	See Ordering Information
Nonlinearity	±0.02% Span
Stability	
Offset	±20ppm/°C
Gain	±50ppm/°C
Noise	
Output, 100kHz	250μVrms
Bandwidth, -3dB	3Hz
Response Time, 90% Span	150ms
Output Range	0V to +5V
Output Protection	Continuous Short to Ground
Transient	ANSI/IEEE C37.90.1
Cold Junction Compensation	
Accuracy, 25°C	±0.5°C
Accuracy, -40°C to +85°C (J,K,T)	±1.5°C
Accuracy, -20°C to +65°C (R,S)	±3.0°C
Accuracy, -40°C to +85°C (R,S)	±5.0°C
Power Supply Voltage	+5VDC ±5%
Power Supply Current	30mA
Power Supply Sensitivity	±25ppm/%
Mechanical Dimensions (h)(w)(d)	1.11" x 1.65" x 0.40" (28.1mm x 41.9mm x 10.2mm)
Environmental	
Operating Temp. Range	-40°C to +85°C
Storage Temp. Range	-40°C to +85°C
Relative Humidity	0 to 95% Noncondensing
Emissions EN61000-6-4	ISM, Group 1
Radiated, Conducted	Class A
Immunity EN61000-6-2	ISM, Group 1
RF	Performance A ±0.5% Span Error
ESD, EFT, Surge, Voltage Dips	Performance B

**NOTES:**

(1) 240VAC between + and - / +EXC / -EXC terminals. 120VAC between - and +EXC / -EXC terminals and between +EXC and -EXC terminals.

(2) Includes nonlinearity, hysteresis and repeatability. Does not include CJC accuracy.

**Ordering Information**

Model	TC Type <sup>‡</sup>	Input Range	Output Range	Accuracy <sup>(2)</sup>	
8B37J	J	-100°C to +760°C (-148°F to +1400°F)	0V to +5V	±0.05%	±0.43°C
8B37K	K	-100°C to +1350°C (-148°F to +2462°F)	0V to +5V	±0.05%	±0.73°C
8B37T	T	-100°C to +400°C (-148°F to +752°F)	0V to +5V	±0.05%	±0.25°C
8B37R	R	0°C to +1750°C (+32°F to +3182°F)	0V to +5V	±0.05%	±0.88°C
8B37S	S	0°C to +1750°C (+32°F to +3182°F)	0V to +5V	±0.05%	±0.88°C

**‡ Thermocouple Alloy Combinations**

Standards: DIN IEC 584, ANSIC96-1-82, JIS C 1602-1981

Type	Material
J	Iron vs. Copper-Nickel
K	Nickel-Chromium vs. Nickel-Aluminum
T	Copper vs. Copper-Nickel
R	Platinum-13% Rhodium vs. Platinum
S	Platinum-10% Rhodium vs. Platinum