

DSCT30/31



Analog Voltage Input Transmitters

Description

Each DSCT30 and DSCT31 voltage input transmitter provides a single channel of analog input which is filtered, isolated, amplified, and converted to a process current output (Figure 1). Signal filtering is accomplished with a five-pole filter, which provides 85dB of normal-mode-rejection at 60Hz and 80dB at 50Hz. An anti-aliasing pole is located on the field side of the isolation barrier, and the other four are on the process loop side. After the initial field-side filtering, the input signal is chopped by a proprietary chopper circuit. Isolation is provided by transformer coupling, again using a proprietary technique to suppress transmission of common mode spikes or surges.

Special input and output circuits on the DSCT30 and DSCT31 transmitters provide protection against accidental connection of power-line voltages up to 240VAC and against transient events as defined by ANSI/IEEE C37.90.1. Signal and loop power lines are secured to the module using screw terminals, which are in pluggable terminal blocks for ease of system assembly and reconfiguration.

The modules have excellent stability over time and do not require recalibration, however, zero and span settings are adjustable up to $\pm 10\%$ to accommodate situations where fine-tuning is desired. The adjustments are made using potentiometers located under the front panel label and are non-interactive for ease of use.

► Features

- Accepts Millivolt and Voltage Level Signals
- Process Current Output
- 1500Vrms Transformer Isolation
- ANSI/IEEE C37.90.1 Transient Protection
- Input and Output Protected to 240VAC Continuous
- Up to 60V Loop Voltage
- 160dB CMR
- 85dB NMR at 60Hz, 80dB at 50Hz
- $\pm 0.03\%$ Accuracy
- $\pm 0.01\%$ Linearity
- Easily Mounts on Standard DIN Rail
- CSA and FM Approvals Pending
- CE Compliant

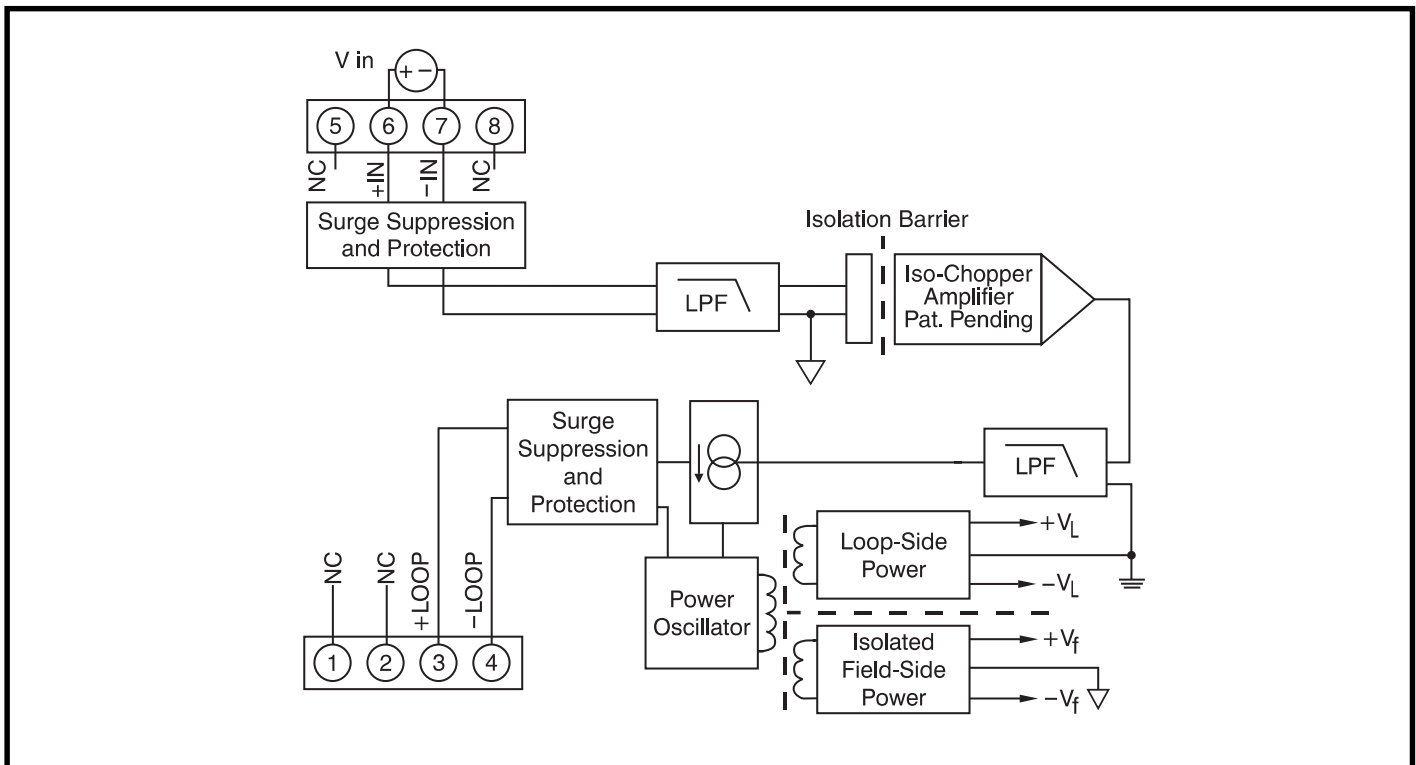

Figure 1: DSCT30/31 Block Diagram

Specifications Typical at $T_A = +25^\circ\text{C}$ and +24V loop voltage

Model	DSCT30	DSCT31
Input Range	$\pm 10\text{mV}$ to $\pm 100\text{mV}$	$\pm 1\text{V}$ to $\pm 20\text{V}$
Input Bias Current	$\pm 0.5\text{nA}$	$\pm 0.05\text{nA}$
Input Resistance		
Normal	$50\text{M}\Omega$	$2\text{M}\Omega$
Power Off	$66\text{k}\Omega$	$2\text{M}\Omega$
Overload	$66\text{k}\Omega$	$2\text{M}\Omega$
Input Protection		
Continuous	240Vrms max	*
Transient	ANSI/IEEE C37.90.1	*
CMV, Input to Output		
Continuous	1500Vrms max	*
Transient	ANSI/IEEE C37.90.1	*
CMR (50Hz or 60Hz)	160dB	*
NMR	85dB at 60Hz, 80dB at 50Hz	*
Adjustability	$\pm 10\%$ Zero and Span	*
Accuracy ⁽¹⁾	$\pm 0.03\%$	*
Conformity	$\pm 0.01\%$	*
Stability		
Offset	$\pm 20\text{ppm}/^\circ\text{C}$	*
Gain	$\pm 80\text{ppm}/^\circ\text{C}$	*
Noise		
Output, 100kHz	$3\mu\text{Arms}$	*
Bandwidth, -3dB	3Hz	*
Response Time, 90% Span	165ms	*
Output Range	4mA to 20mA	*
Output Limits		
Under-range	2.8mA	*
Over-range	29mA	*
Output Protection		
Reverse Polarity	Continuous	*
Over-voltage	240Vrms continuous	*
Transient	ANSI/IEEE C37.90.1	*
Loop Supply Voltage	10.8V to 60V	*
Loop Supply Sensitivity	$\pm 0.0005\%/V$	*
Turn-On Delay	400ms	*
Environmental		
Operating Temp. Range	-40°C to $+80^\circ\text{C}$	*
Storage Temp. Range	-40°C to $+80^\circ\text{C}$	*
Relative Humidity	0 to 95% Noncondensing	*
Emissions	EN50081-1, ISM Group 1, Class A (Radiated, Conducted)	*
Immunity	EN50082-1, ISM Group 1, Class A (ESD, RF, EFT)	*
Mechanical Dimensions	$2.95" \times 0.89" \times 4.13"$	*
(h)(w)(d)	$(75\text{mm} \times 22.5\text{mm} \times 105\text{mm})$	*
Mounting	DIN EN 50022 -35x7.5 or -35x15 rail	*

NOTES:

* Same specification as DSCT30.

(1) Includes nonlinearity, hysteresis and repeatability.

Ordering Information

Model	Input Range
DSCT30-01	$\pm 10\text{mV}$
DSCT30-02	$\pm 50\text{mV}$
DSCT30-03	$\pm 100\text{mV}$
DSCT30-04	0 - 10mV
DSCT30-05	0 - 50mV
DSCT30-06	0 - 100mV
DSCT31-01	$\pm 1\text{V}$
DSCT31-02	$\pm 5\text{V}$
DSCT31-03	$\pm 10\text{V}$
DSCT31-04	0 - 1V
DSCT31-05	0 - 5V
DSCT31-06	0 - 10V
DSCT31-07	$\pm 20\text{V}$
DSCT31-08	0 - 20V