

DSCT36

Potentiometer Input Transmitters



Description

Each DSCT36 potentiometer input transmitter provides a single channel of potentiometer input which is filtered, isolated, amplified, and converted to a process current output (Figure 1). Signal filtering is accomplished with a five-pole filter, which provides 85dB of normal-mode-rejection at 60Hz and 80dB at 50Hz. An anti-aliasing pole is located on the field side of the isolation barrier, and the other four are on the process loop side. After the initial field-side filtering, the input signal is chopped by a proprietary chopper circuit. Isolation is provided by transformer coupling, again using a proprietary technique to suppress transmission of common mode spikes or surges.

Potentiometer excitation is provided from the transmitter using a precision current source. The excitation current is small (less than 0.26mA) which minimizes self-heating of the potentiometer. Lead compensation is achieved by matching two current paths which cancels the effects of lead resistance.

Special input and output circuits on the DSCT36 transmitters provide protection against accidental connection of power-line voltages up to 240VAC and against transient events as defined by ANSI/IEEE C37.90.1. Signal and loop power lines are secured to the module using screw terminals, which are in pluggable terminal blocks for ease of system assembly and reconfiguration.

The modules have excellent stability over time and do not require recalibration, however, zero and span settings are adjustable up to $\pm 10\%$ to accommodate situations where fine-tuning is desired. The adjustments are made using potentiometers located under the front panel label and are non-interactive for ease of use.

► Features

- Interfaces to Potentiometers up to 10k Ω
- Process Current Output
- 1500Vrms Transformer Isolation
- ANSI/IEEE C37.90.1 Transient Protection
- Input and Output Protected to 240VAC Continuous
- Up to 60V Loop Voltage
- 160dB CMR
- 85dB NMR at 60Hz, 80dB at 50Hz
- $\pm 0.03\%$ Accuracy
- $\pm 0.01\%$ Linearity
- Easily Mounts on Standard DIN Rail
- CSA and FM Approvals Pending
- CE Compliant

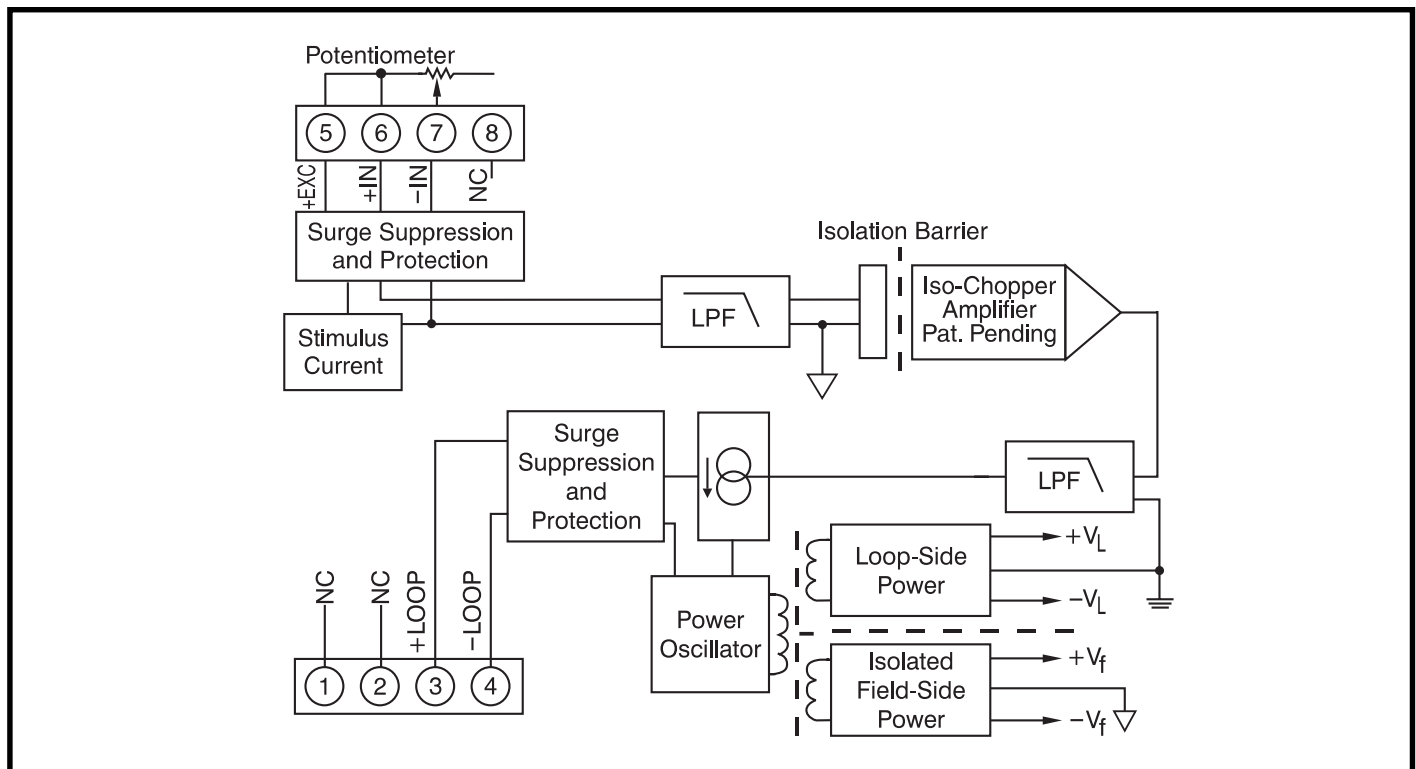

Figure 1: DSCT36 Block Diagram

Specifications Typical at $T_A = +25^\circ\text{C}$ and +24V loop voltage

Module	DSCT36
Input Range	0 Ω to 10k Ω
Input Resistance	
Normal	50M Ω
Power Off	66k Ω
Overload	66k Ω
Input Protection	
Continuous	240Vrms max
Transient	ANSI/IEEE C37.90.1
CMV, Input to Output	
Continuous	1500Vrms max
Transient	ANSI/IEEE C37.90.1
CMR (50Hz or 60Hz)	160dB
NMR	85dB at 60Hz, 80dB at 50Hz
Adjustability	$\pm 10\%$ Zero and Span
Accuracy ⁽¹⁾	$\pm 0.03\%$
Conformity	$\pm 0.01\%$
Stability	
Offset	$\pm 50\text{ppm}/^\circ\text{C}$
Gain	$\pm 100\text{ppm}/^\circ\text{C}$
Sensor Excitation Current	0.26mA; 100 Ω , 500 Ω Sensor 0.13mA; 1k Ω Sensor 0.065mA; 10k Ω Sensor
Lead Resistance Effect	$\pm 0.01\Omega/\Omega$; 100 Ω , 500 Ω , 1k Ω Sensor $\pm 0.02\Omega/\Omega$; 10k Ω Sensor
Noise	
Output, 100kHz	3 μArms
Bandwidth, -3dB	3Hz
Response Time, 90% Span	165ms
Output Range	4mA to 20mA
Output Limits	
Under-range	3mA
Over-range	29mA
Output Protection	
Reverse Polarity	Continuous
Over-voltage	240Vrms Continuous
Transient	ANSI/IEEE C37.90.1
Loop Supply Voltage	10.8V to 60V
Loop Supply Sensitivity	$\pm 0.0005\%/V$
Turn-On Delay	400ms
Environmental	
Operating Temp. Range	-40 $^\circ\text{C}$ to +80 $^\circ\text{C}$
Storage Temp. Range	-40 $^\circ\text{C}$ to +80 $^\circ\text{C}$
Relative Humidity	0 to 95% Noncondensing
Emissions	EN50081-1, ISM Group 1, Class A (Radiated, Conducted)
Immunity	EN50082-1, ISM Group 1, Class A (ESD, RF, EFT)
Mechanical Dimensions (h)(w)(d)	2.95" x 0.89" x 4.13" (75mm x 22.5mm x 105mm)
Mounting	DIN EN 50022 -35x7.5 or -35x15 rail

NOTES:

(1) Includes nonlinearity, hysteresis and repeatability.

Ordering Information

Model	Input Range
DSCT36-01	0 to 100 Ω
DSCT36-02	0 to 500 Ω
DSCT36-03	0 to 1k Ω
DSCT36-04	0 to 10k Ω