

NAGASAKI PPC-1594T-SB-FL

15" Rugged Steel Fanless Panel PC, Intel new-generation 45nm 100% Fanless high speed 1.6GHz CPU, Touch, DDR2 high speed RAM, Anti-shock slim HDD, VGA, 3D graphics engine, LAN, 8 x USB, 1 x COM, PCI slot, CD-RW, 2x Speakers, PS/2 KB, PS/2 Mouse, industrial-grade power supply.

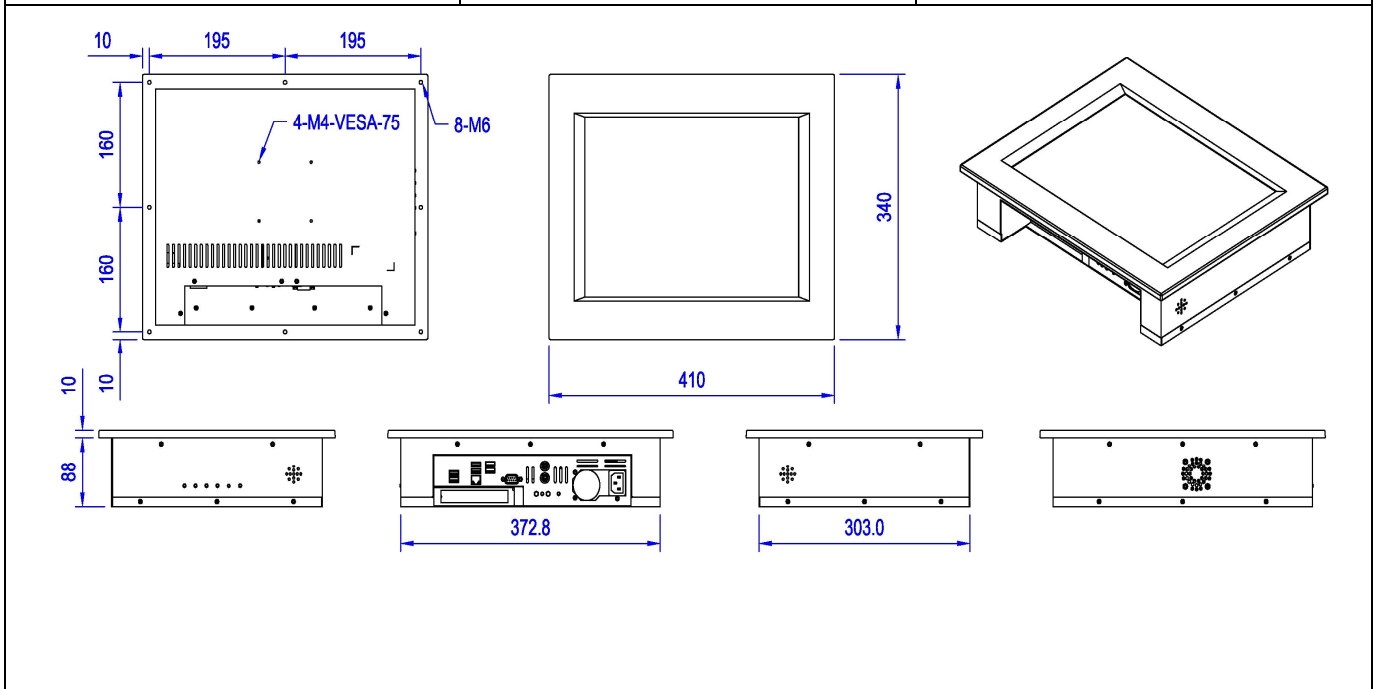

CPU :

Support Intel new-generation 45nm ultra low power fanless 1.6GHz processor.

LCD Panel

15" TFT LCD, 1024 x 768 resolutions. There are several different brightness LCD for your selection :

Standard brightness : 300 cd/m²

Option 1 : 450 cd/m²

Option 2 : 600 cd/m² transfective sunlight-readable display

Option 3 : 900 cd/m² transfective sunlight-readable display

Option 4 : 1700 cd/m² super bright sunlight-readable display

No. of Colors :

16.77 Million colors

Housing

Rugged steel construction chassis for harsh environment.

Touch Screen :

The standard touch screen is 5-Wire Resistive Touch, 4096 x 4096 high resolution.

Option 1 : Capacitive Touch

Option 2 : SAW Touch

Option 3 : IR Touch (IR is Infra-Red)

Option 4 : Vandal-Proof Resistive Touch

Option 5 : Vandal-Proof Capacitive Touch

Option 6 : Vandal-Proof SAW Touch

Industrial grade quality

This is an industrial grade main board.

Memory (system) :

One 240-pin DDR2 DIMM memory socket supporting DDR2 533, 667, and 800 MHz high speed memory up to 1 GB.

Video chipset :

Intel 945GM Integrated GMA950 graphic engine supporting high speed 3D graphics acceleration. .

3D High speed Graphics chip :

The Intel GMA950 graphic engine support high speed 3D graphics acceleration. Support 256MB share video memory

Dual Independent Display :

This Panel PC support two different displays with two different images at the same time.

Speakers / Audio:

RealTek ALC888 High-Definition Audio chip on-board. Two Audio-Jack on rear for Audio Line-OUT and MIC.

LAN (Ethernet) Network

1 x RJ-45 Ethernet port support 10/100 Mbps LAN network activity .

IDE Port :

1 IDE port support CD-ROM, HDD, DOM, etc.

SATA-II Port :

2 x SATA-II port support 2 high speed SATA-II HDD, CD-ROM, DOM, etc.

HDD :

Support slim type SATA-II high speed HDD. Standard HDD is 80GB anti-shock slim HDD. 160GB is option. .

CD-RW :

This is an optional item - slim size CD-ROM, CD-RW.

Option 1 : slim size DVD-ROM.

Option 2 : slim size DVD-RW

Serial ports (i.e. COM)

There is one serial port (COM) supporting RS232.

USB 2.0 port :

There are 8 x USB 2.0 ports in total. 6 x USB are located at the I/O port area. 2 x USB are hidden inside chassis reserving for touch interface connection.

Keyboard port

1 x PS/2 keyboard port support PS2 keyboard

Mouse port

1 x PS/2 mouse port support t PS/2 mouse

Power consumption :

The power consumption of this 15" Panel PC is 58 Watts (fanless).

Printer port

1 x PS/2 mouse and 1 x PS/2 keyboard port at the I/O area

Audio Port :

The pink audio port support Microphone-In.

The green audio port support Line-Out – speakers

The light blue audio port support Line-In audio device.

PCI slot :

For 12, 15, 17, 19" : there is one PCI slot for expansion.

For 10" or smaller size ; there is no PCI expansion slot.

Wall-mount :

Support VESA-75 wall mount standard.

VESA-75 wall-mount kit is available for option with extra cost.

IP-65 & NEMA-4 rating :

Meet IP-65 and NEMA-4 water and dust resisting ratings at front face.

Option : Entire IP-65 rated is available for your request.

Operating Temperature :

0 degree C to +60 degree C (fanless)

Option 1 : with cooling fan, it can support up to +75 degree C

Option 2 : with NAGASAKI patented heater module, it can

support PPC boot up from -20 degree C cold weather.

Vibration Resistance

Meet all types of industrial vibration standard. 5 – 500 Hz at 2G random vibration life test under Windows XP operation.

Shock Resistance

Meet all types of industrial standards. (10, 15, 20, 25G)

Military standard is also available at your request.

Power Supply :

Universal switching power supply supporting AC 100 – 260V.

Meet CE, FCC, UL, RoHS approvals

Order Information :

PPC-1594T-FL : Intel 1.6GHz 100% Fanless Touch Panel PC, metal

PPC-1594T-FL-IP : same as above, but entire housing is IP-65 rated for water and dust resistant.

PPC-1594T-AL-FL : same as 1594T-FL, but with aluminum bezel

PPC-1594T-AL-SUN : same as above, but with sunlight-readable LCD for outdoor application under sunlight.

Please note : The above are only a few models. There are many other models available for various different applications for example Military, Industrial, Train, Bus, Truck, Ships, gas station, airport, home, hospital, hotel, ...etc.